

## Technical Data Sheet

### High Power Infrared LED

#### HC-HIR3030/L836-U120-P01/TR

#### Features

- Small package with high efficiency
- Peak wavelength  $\lambda_p = 850$  nm
- Soldering methods: SMT
- Pb free
- Compliance with EU REACH
- Compliance Halogen Free(Br < 900ppm, Cl < 900ppm, Br+Cl < 1500ppm)
- The product itself will remain within RoHS compliant version.

#### Description

- The device is spectrally matched with silicon photo diode and phototransistor.

#### Applications

- Infrared applied system

#### Device Selection Guide

LED Part No.	Chip Material	Lens Color
HC-HIR3030/L836-U120-P01/TR	GaAlAs	Water clear

## Absolute Maximum Ratings ( $T_A=25^\circ\text{C}$ )

Parameter	Symbol	Rating	Unit
Continuous Forward Current	$I_F$	500	mA
Reverse Voltage	$V_R$	5	V
Operating Temperature	$T_{opr}$	-40 ~ +100	$^\circ\text{C}$
Storage Temperature	$T_{stg}$	-40 ~ +100	$^\circ\text{C}$
Junction temperature	$T_j$	115	$^\circ\text{C}$

Notes: We suggest that customer should add the heat sink with HC-HIR3030/L836-U120-P01/TR to exclude the heat.

## Electro-Optical Characteristics ( $T_A=25^\circ\text{C}$ )

Parameter	Symbol	Min.	Typ.	Max.	Unit	Condition
Total Radiated Power	$P_o$		290		mW	$I_F=500\text{ mA}$
Radiant Intensity	$I_E$		90		mW/sr	$I_F=500\text{ mA}$
Peak Wavelength	$\lambda_P$	--	850	--	nm	$I_F=350\text{ mA}$
Spectral Bandwidth	$\Delta\lambda$	--	25	--	nm	$I_F=350\text{ mA}$
Forward Voltage	$V_F$		1.80		V	$I_F=500\text{ mA}$
Reverse Current	$I_R$	--	--	10	$\mu\text{A}$	$V_R=5\text{ V}$
View Angle	$2\theta_{1/2}$	--	120	--	deg	$I_F=20\text{ mA}$

## Typical Electro-Optical Characteristics Curves

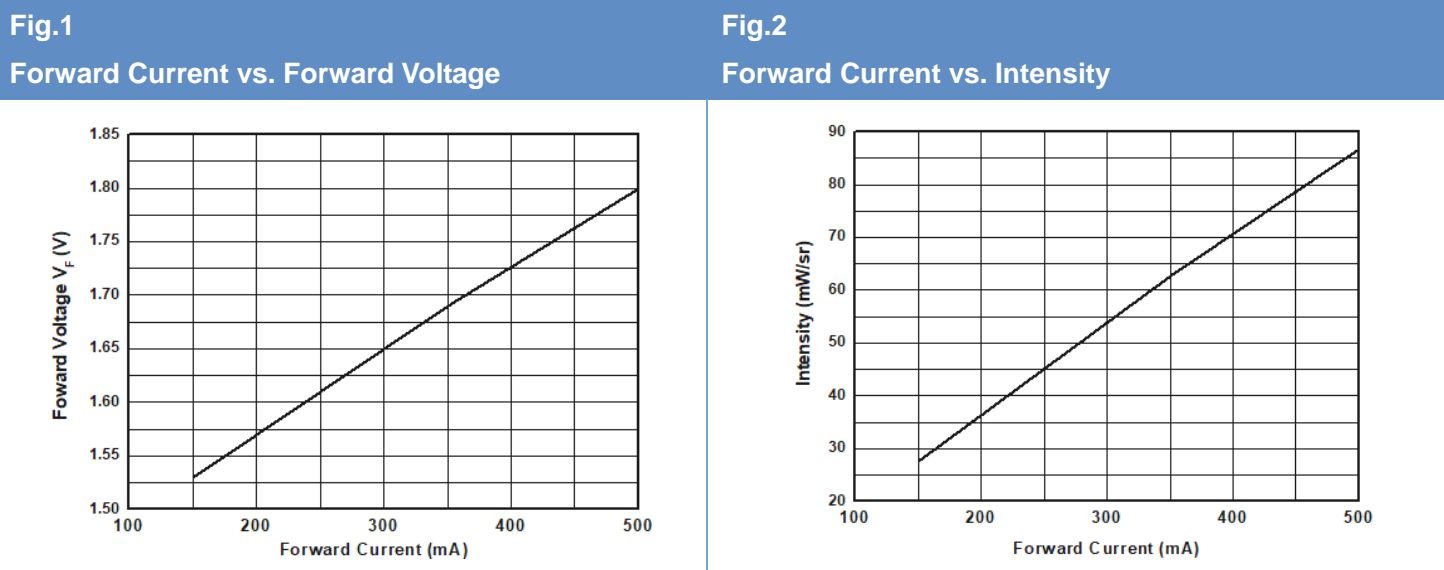

Fig.3  
Forward Current vs. Total Power

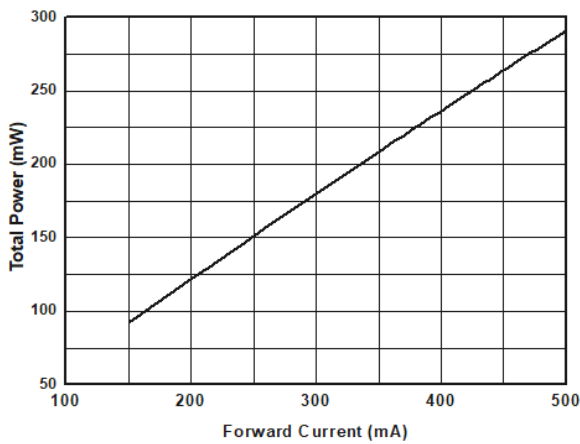

Fig.4  
Relative Radiant Intensity vs. Angular Displacement

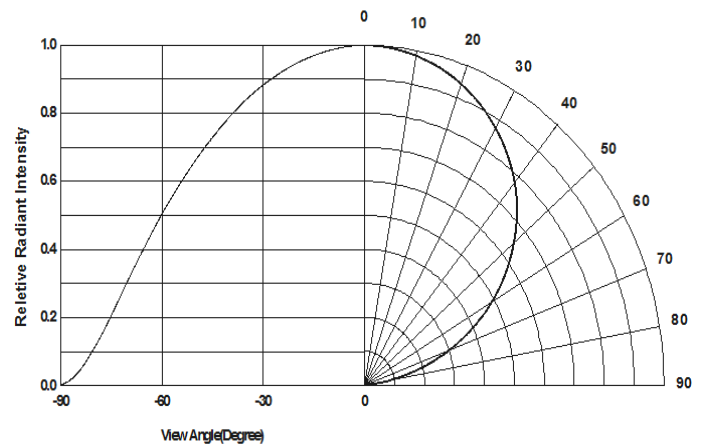

Fig.5  
Relative Forward Voltage vs. Ambient Temperature

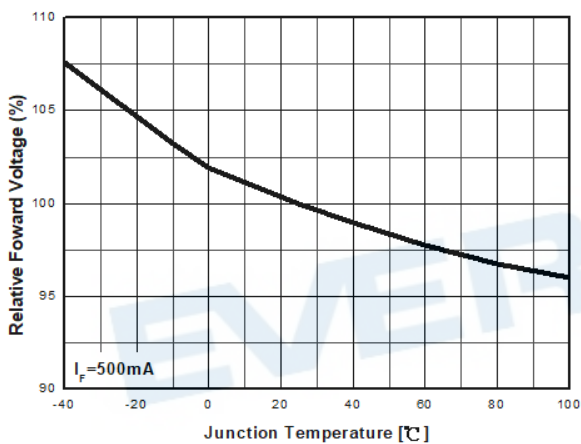

Fig.6  
Relative Radiant Intensity vs. Ambient Temperature

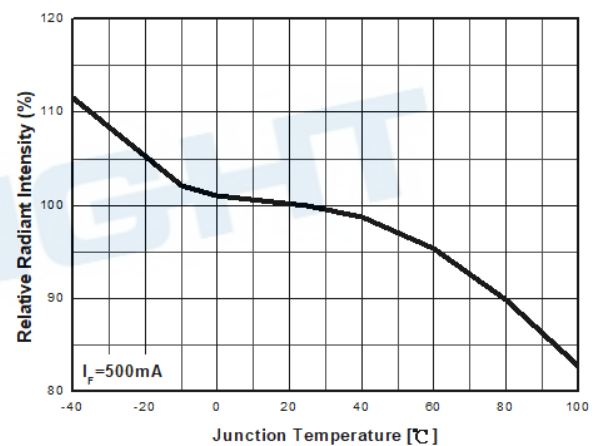
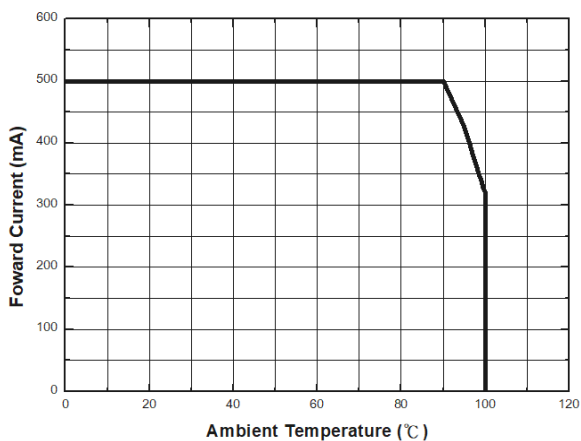
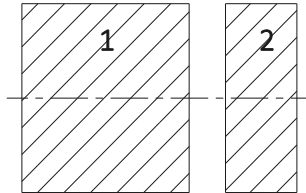

Fig.7  
Forward Current vs. Ambient Temperature



## Pad Configuration

Pad	1	2
Function	Anode	Cathode



## Package Dimension

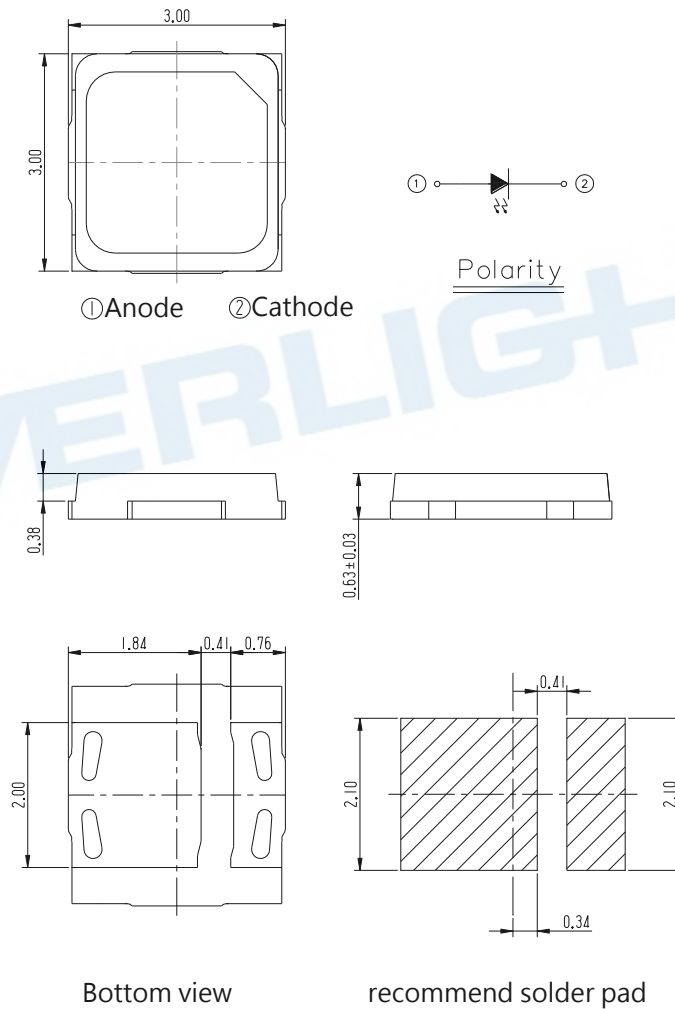

1. Dimensions are in millimeters.
2. Tolerances unless mentioned are  $\pm 0.1\text{mm}$ .
3. Do not handle the device by the lens. Incorrect force applied to the lens may lead to the failure of devices.

## Reflow Soldering Characteristics

### For Reflow Process

1. 3030 series are suitable for SMT processes.
2. Curing of glue in oven must be according to standard operation flow processes.

Profile Feature	Lead Free Assembly	Unit
Ramp-Up Rate	2~3	°C/S
Preheat Temperature	150~200	°C
Preheat Time( $t_s$ )	60~120	S
Liquid Temperature( $T_L$ )	217	°C
Time maintained above $T_L$	60~90	S
Peak Temperature( $T_P$ )	240±5	°C
Peak Time ( $t_P$ )	Max 20	S
Ramp-Down Rate	3~5	°C/S

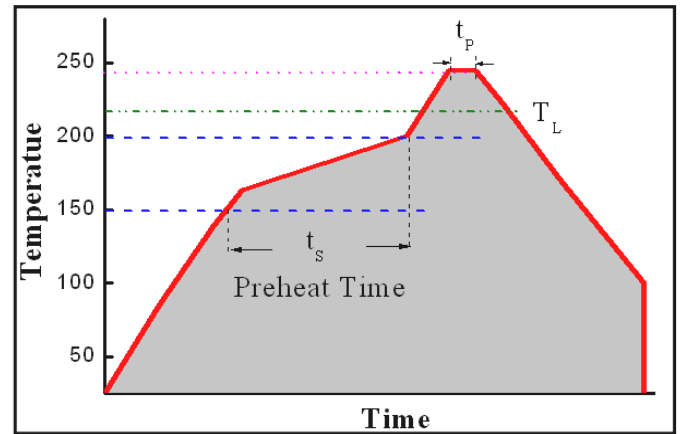

3. Reflow soldering should not be done more than twice.
4. In soldering process, stress on the LEDs during heating should be avoided.
5. After soldering, do not bend the circuit board.

## Package Dimensions

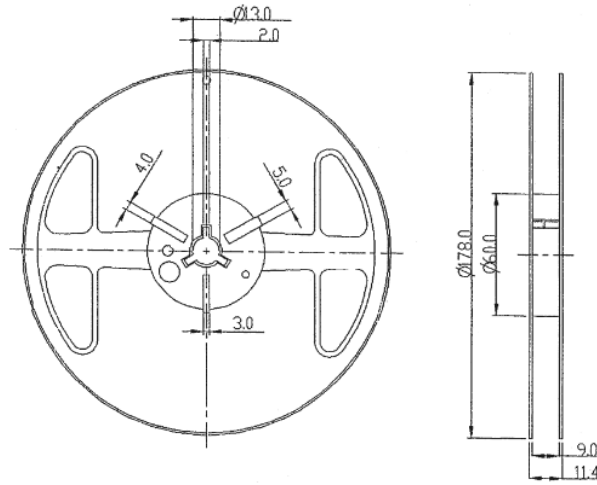

Note:

1. Dimensions are in millimeters
2. The tolerances unless mentioned is  $\pm 0.1\text{mm}$

## Carrier Tape Dimensions:

Loaded quantity 2000 pcs per reel.

### Feeding Direction

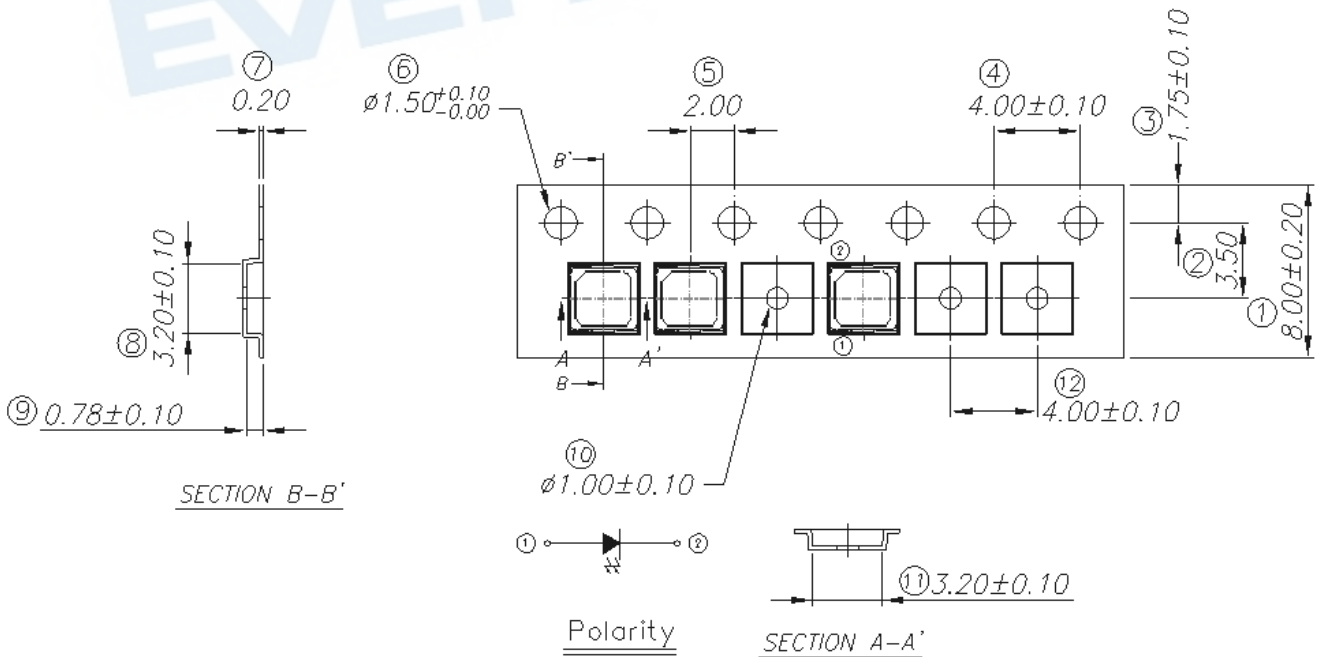

Note:

1. Dimensions are in millimeters
2. The tolerances unless mentioned is  $\pm 0.1\text{mm}$

## Moisture Resistant Packaging

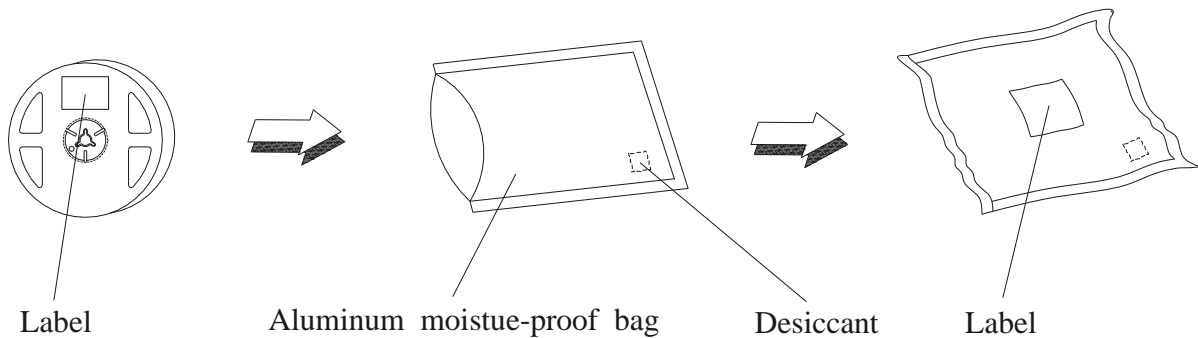

## Moisture Resistant Packing Materials

### Label Form Specification

RoHS  <b>EVERLIGHT</b>	
CPN : XXXXXXXXXX-XXXXXXXXXX-XXXXXXXXXX-XXXXXXXXXX-XXXXXX	
P/N : XXXXXXXXXX-XXXXXXXXXX-XXXXXXXXXX-XXXXXXXXXX-XXXXXX	
LOT NO : XXXXXXXXXX-XXXXXXXXXX-XXXXXXXXXX-XXXXXXXXXX-XXXXXX	
QTY :	HUE :
CAT :	REF :
REFERENCE :	
Made In XXXXX	

- CPN: Customer's Product Number
- P/N: Product Number
- QTY: Packing Quantity
- CAT: Luminous Intensity Rank
- HUE: Dom. Wavelength Rank
- REF: Forward Voltage Rank
- LOT No: Lot Number
- X: Month
- Reference: Identify Label Number

**EVERLIGHT ELECTRONICS CO., LTD.**

Office: No 6-8, Zhonghua Rd., Shulin Dist.,

Tel: 886-2-2685-6688

Fax: 886-2-2685-6897

## DISCLAIMER

1. EVERLIGHT reserves the right(s) on the adjustment of product material mix for the specification.
2. The product meets EVERLIGHT published specification for a period of twelve (12) months from date of shipment.
3. The graphs shown in this datasheet are representing typical data only and do not show guaranteed values.
4. When using this product, please observe the absolute maximum ratings and the instructions for using outlined in these specification sheets. EVERLIGHT assumes no responsibility for any damage resulting from the use of the product which does not comply with the absolute maximum ratings and the instructions included in these specification sheets.
5. These specification sheets include materials protected under copyright of EVERLIGHT. Reproduction in any form is prohibited without obtaining EVERLIGHT's prior consent.
6. This product is not intended to be used for military, aircraft, automotive, medical, life sustaining or life saving applications or any other application which can result in human injury or death. Please contact authorized Everlight sales agent for special application request.